

Portable Mid-Rise



6,000 lb.
lifting capacity

Portability means Versatility

- Challenger Lifts' Portable Mid-Rise Lift is a great way to increase the productivity in a shop. It's like having a service bay anywhere, indoors or out.
- The motor is conveniently mounted to a heavy-duty tow dolly, making it easy to move and operate on almost any solid surface.
- Exclusive features include a sliding/rotating arm design with rubber pads, low drive-over clearance, and much more.

Challenger Lifts

Features:

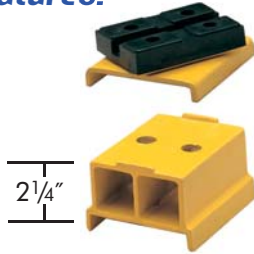

Slip-On Adapter Kit Included:

The Portable Mid-Rise Lift comes with four Rubber Pad Adapters and "Height Extension".

Power Unit Features:

Convenient single push button power unit raises lift and a release valve handle lowers it.



Optional Accessories:

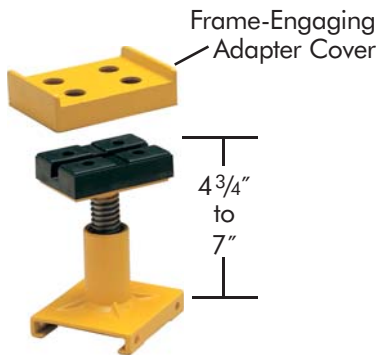

66100

Four Adjustable Screw Adapters for higher frame vehicles. Adapters incorporate rubber pads to protect a vehicle's delicate undercoating.

Four "Frame Engaging" Adapter Covers also included.

66000

Specifications

A. Rise Height	48" (1219mm)
B. Length Overall	7' 6" (2286mm)
C. Width Overall	3' 3 3/8" (1000mm)
D. Min. Collapsed Height	3 3/8" (98mm)
E. Pad Height (minimum)	5 1/2" (140mm)
F. Pad Height (maximum)	49 1/2" (552-1016mm)
Lifting Capacity	6,000 lb. (2722kg)
Hydraulic Hose	12' (3658mm)
Safety Lock Positions	4
Electric Motor	1 HP
Voltage	115v
Speed of Rise	45 sec.
Min. Recommended Bay Size	10' x 22' (3048mm x 6706mm)

Standard lift colors are Red (as shown) and Blue

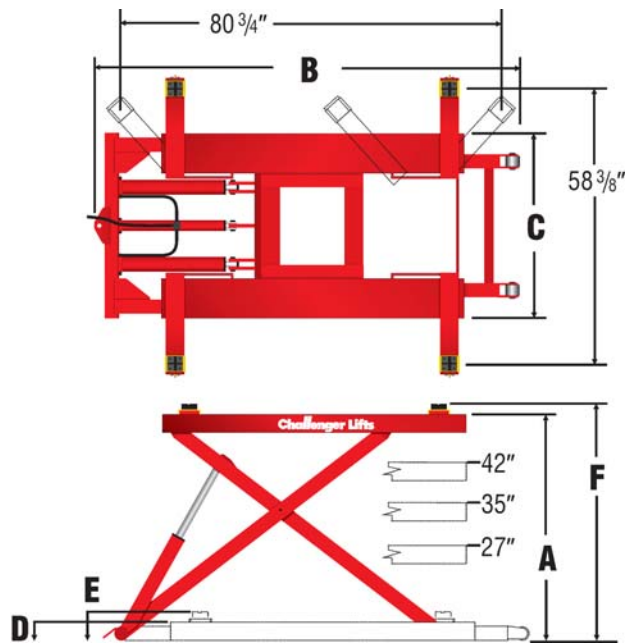

World Leading Quality Standards

Challenger Lifts is a member of the Automotive Lift Institute (ALI). This symbol represents over 50 years of dedication to lift safety by providing rigorous safety standards and training.



CHALLENGER LIFTS, INC.
200 Cabel Street
Louisville, Kentucky 40206

Phone Toll-Free: 800-648-5438
502-625-0700
Fax: 502-625-0711

E-mail: sales@challengerlifts.com

www.challengerlifts.com

Challenger Lifts, Inc. reserves the right to make changes to specifications without notice and without making changes retroactive. Unloading, installation and oil not included.