

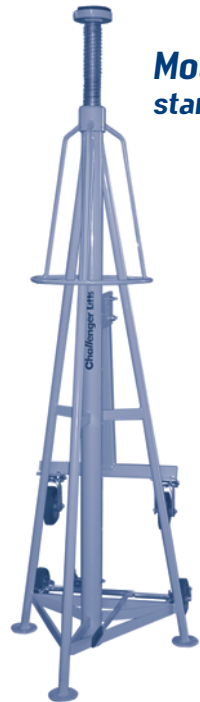

Portable Tailgate Support Stand

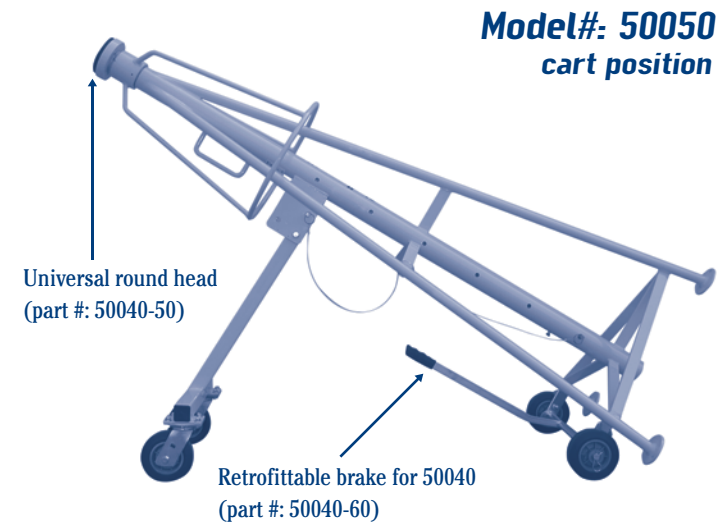

Model#: 50050
stand position



Challenger Lifts' original tailgate support stand is designed to support the tailgate of sanitation trucks while conducting preventative maintenance and repairs to the hydraulic systems.

Features:

- 12,000 lbs. capacity per stand
- 30" triangular base
- Stabilizing brake to ensure accurate and safe placement
- 5 position secondary load holding pin
- Infinitely adjustable height from 7' - 10'
- Universal round head
- New 5½" round contact pad adapter with replaceable rubber insert swivels 360°
- 2½" diameter Square thread double lead screw give 1" height adjustment for each revolution of the nut
- 4 rubber 6" wheels with greaseable roller bearings (2 fixed and 2 swivel casters)
- Stand may be moved like a dolly, using the 2 fixed wheels for short distances or position the double swivel wheeled "drop-leg" to move the like a cart for longer distances

also available:



model#: 50024
17,000 lbs. capacity
adj. 36"-56"



model#: 50018
17,000 lbs. capacity
adj. 60"-80"

Challenger Lifts, Inc.
200 Cabel Street
Louisville, KY 40206

toll free: 800.648.5438
phone: 502.625.0700
fax: 502.625.0711
email: sales@challengerlifts.com

www.challengerlifts.com



Challenger Lifts, Inc. reserves the right to make changes without notice and without making changes retroactive. Unloading, installation not included.

Lit# 50050-11/06
©2006, Challenger Lifts, Inc.